

# All-glass sliding door

## GG00 bottom running

**ATTENTION**

Height compensation without automatic soft stop +/- 6 mm  
 Height compensation with automatic soft stop +/- 6 mm

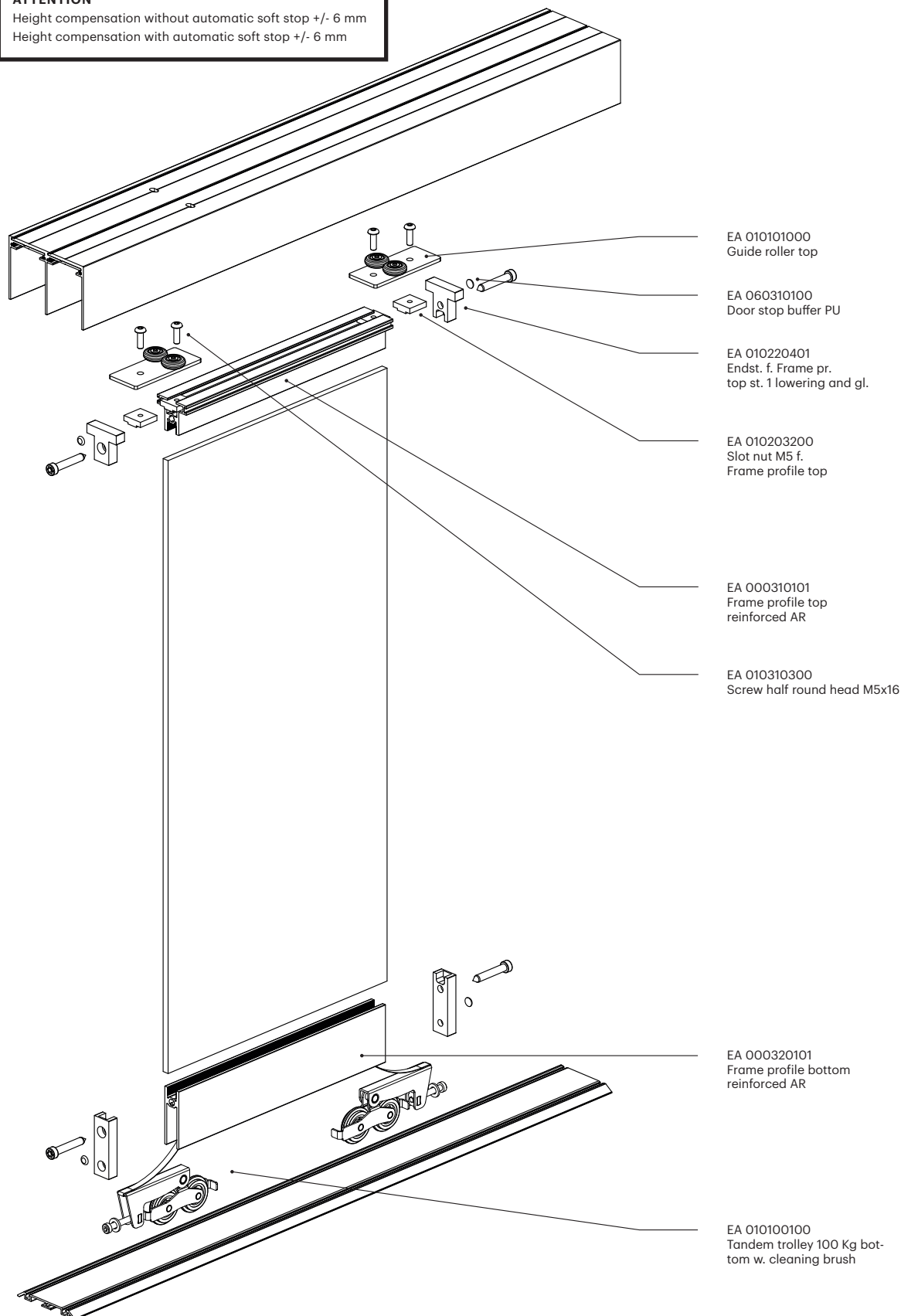

# All-glass sliding door

## GG00 bottom running

**i** All dimensions in millimeters

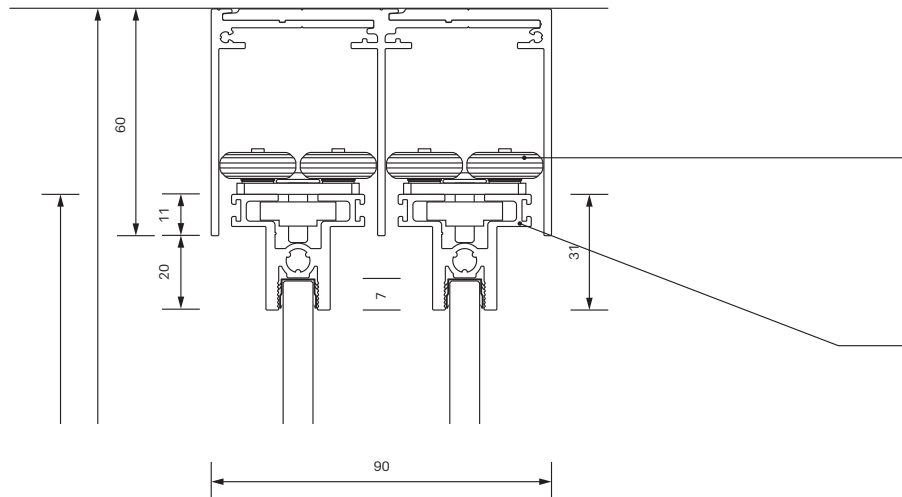

### Wing dimension

Wing width (FB)  
 $AB + (\text{number of projections} \times 30 \text{ mm}) : \text{Number of wings}$

Wing height  
 mounted AH - 59 mm  
 inset AH - 57 mm

### Filling dimension

Filling width

FB

Filling height

mounted AH - 131 mm  
 inset AH - 129 mm

EA 010101000  
 Guide roller top

EA 000310101  
 Frame profile top  
 reinforced AR

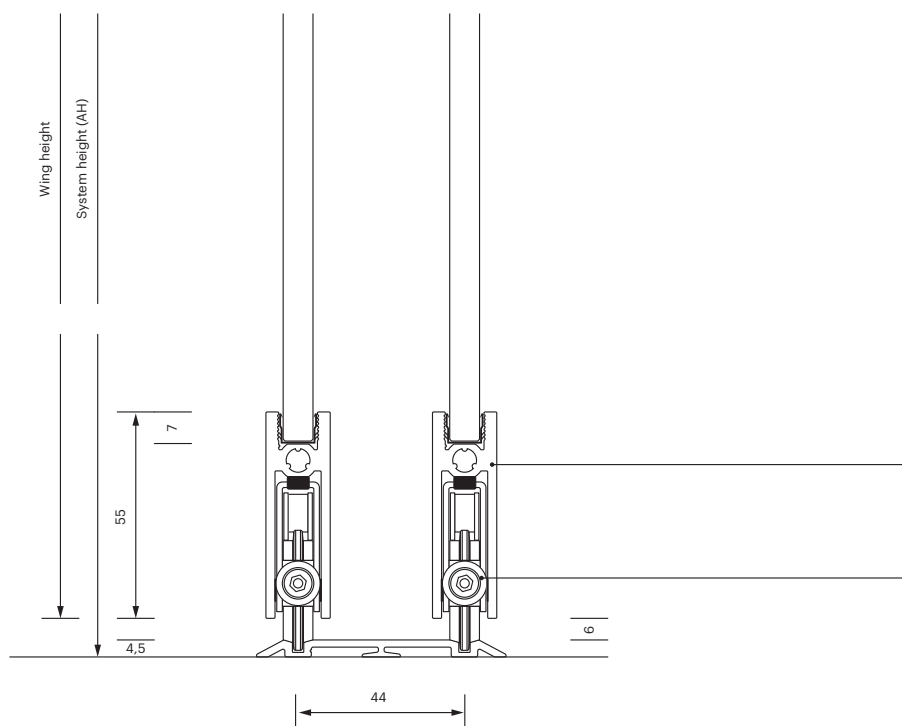

EA 000320101  
 Frame profile bottom  
 reinforced AR

EA 010101000  
 Tandem trolley 100 Kg bot-  
 tom w. cleaning brush

