

# Aluminum frame sliding door

## AR10 bottom running

**ATTENTION**

Height compensation without automatic soft stop +/- 6 mm  
 Height compensation with automatic soft stop +/- 6 mm

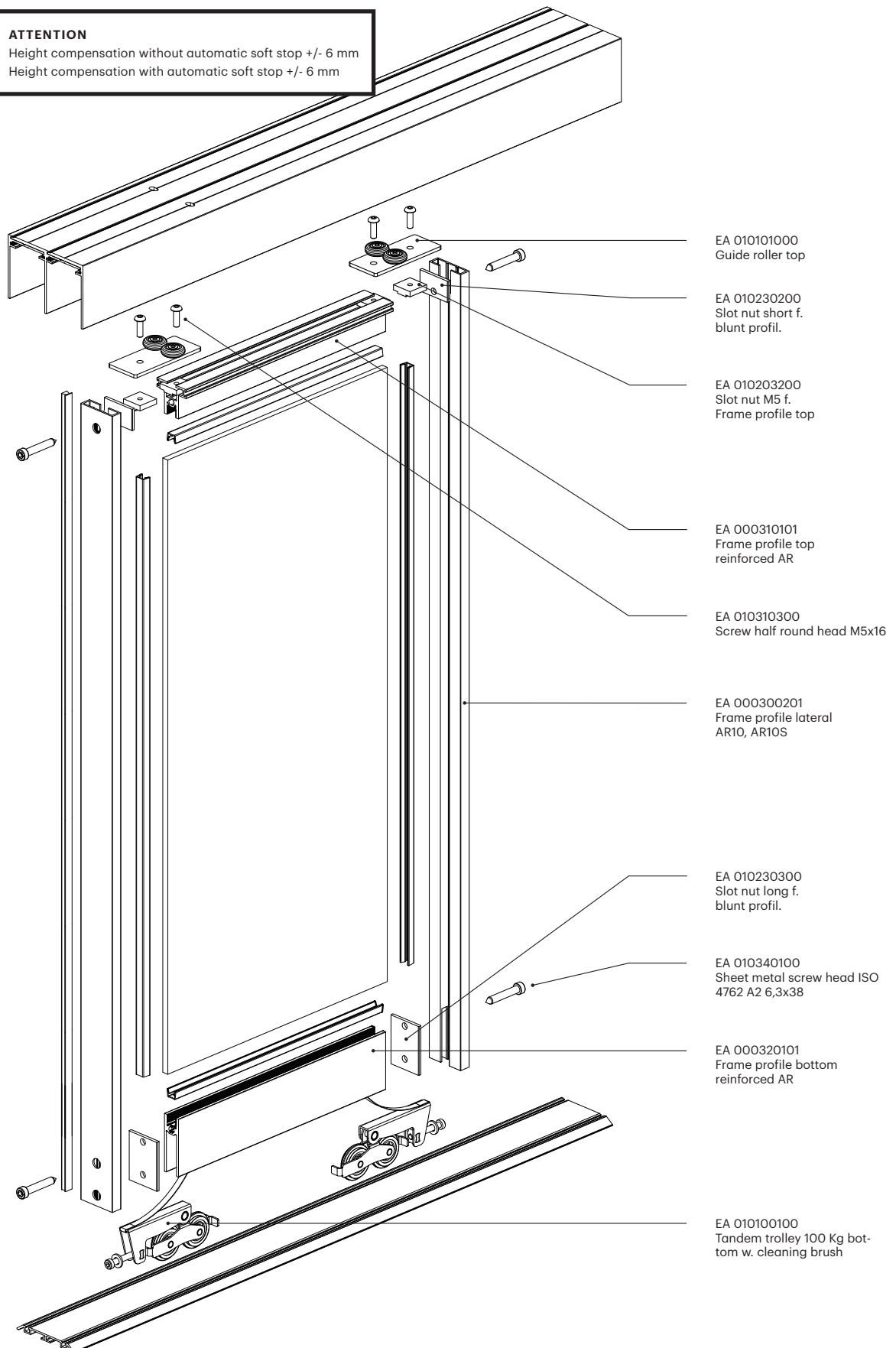

# Aluminum frame sliding door

## AR10 bottom running

**i** All dimensions in millimeters

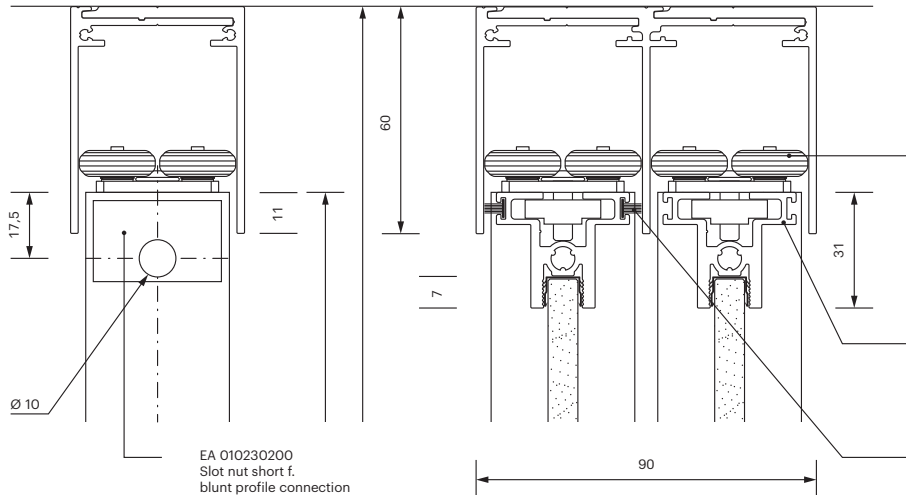

### Wing dimension

Wing width (FB)  
 $AB + (\text{number of projections} \times 10 \text{ mm}) : \text{Number of wings}$

Wing height  
 mounted AH - 59 mm  
 inset AH - 57 mm

### Filling dimension

Filling width  
 FB - 6 mm

Filling height  
 mounted AH - 131 mm  
 inset AH - 129 mm

EA 010101000  
 Guide roller top

EA 000310101  
 Frame profile top  
 reinforced AR

EZ 020200601  
 Brush seal  
 8 mm Gray

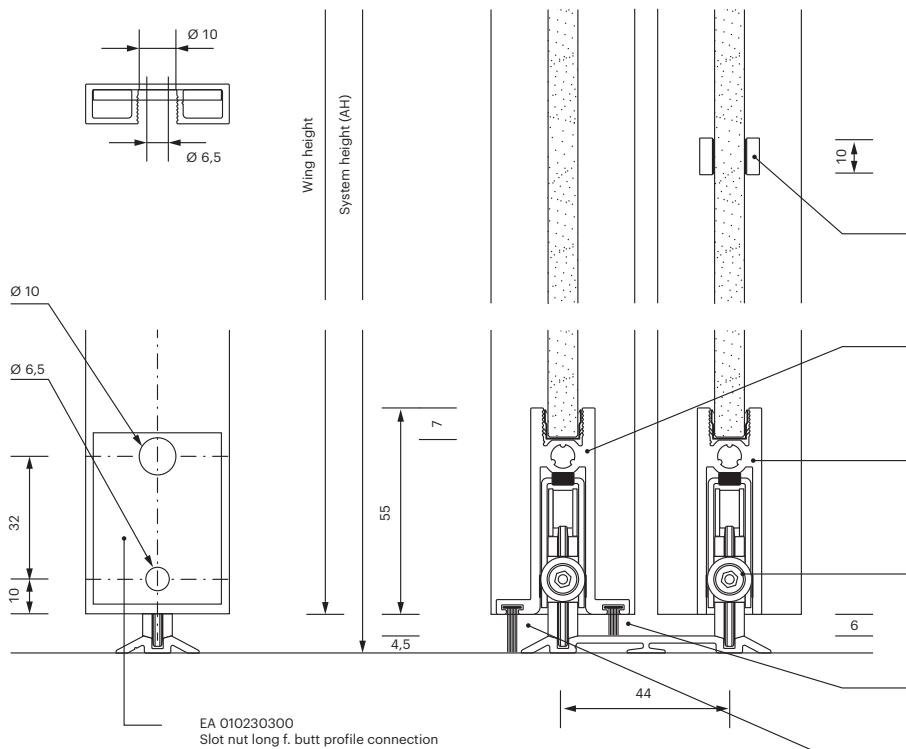

EA 000410201  
 Rung flat profile 10 x 3 mm

EA 000320301  
 Frame profile bottom w.  
 Brush holder AR

EA 000320101  
 Frame profile bottom  
 reinforced AR

EA 010101000  
 Tandem trolley 100 Kg  
 bottom w. cleaning brush

EZ 020200101  
 Brush seal 12 mm Grey

EZ 020200201  
 Brush seal 16 mm Grey

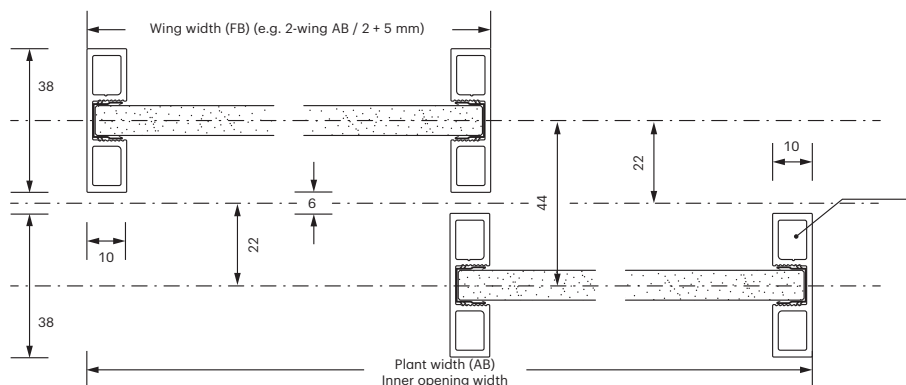

EA 000300201  
 Frame profile lateral  
 AR10, AR10S